



Handling



Dispensing



Sieving



Blending



Container



Cleaning

Transporting. Lifting. Weighing. Mobile Lifter with Weighing System



SERVOLIFT

Your specialist for
complete handling-, blending-
and cleaning technologies

SERVOLIFT GmbH
Albert-Einstein-Straße 9
77656 Offenburg Germany

T. +49 (0) 781 6100 0
F. +49 (0) 781 6100 400

info@servolift.de
www.servolift.de

► Mobile Weighing System

This mobile lifter fulfills all requirements of our customers in just one machine. Feeding several process machines (i.e. coaters) with only one machine, automatic weighing, dustless product transfer, dust aspiration, discharge aid for bad-flowing products, quick and simple assembly and disassembly of the product-contact components.

With this machine SERVOLIFT demonstrates, that it meets all requirements more than enough.

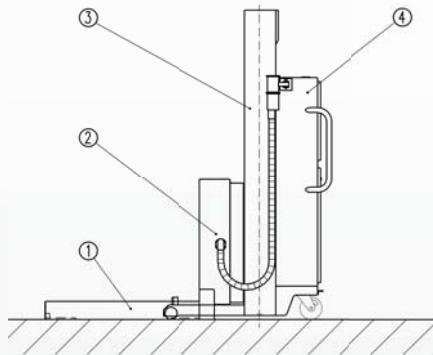

Mobile Lifter

- 1 supporting arm
- 2 frontcase with integrated scale
- 3 column
- 4 cabinet with drive unit, control, operation- and indication terminal and printer

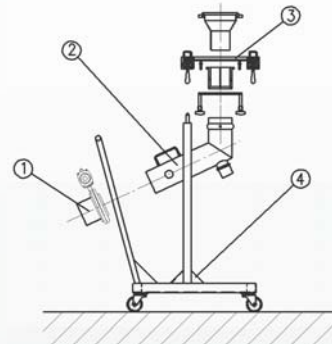

Systemtube

- 1 transfer piece with butterfly-valve and dust cap
- 2 tube with vibrator
- 3 clamping device for discharge tube
- 4 mounting trolley

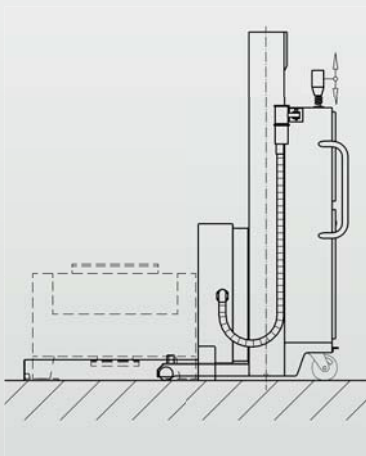

pick-up position
for the container

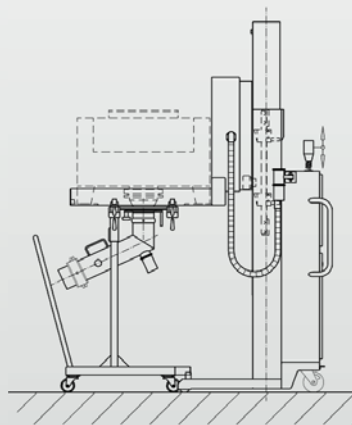

pick-up position
for the systemtube

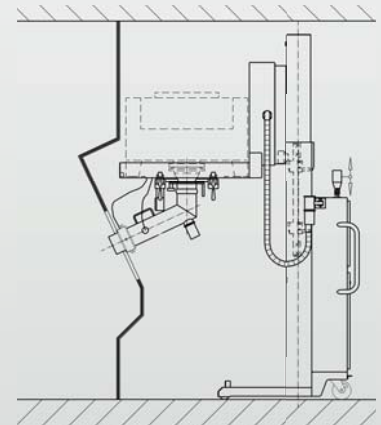

emptying position

Technical data:

load capacity:	300 kg
pick-up height:	10 mm
max. lift height:	1795 mm
height of device:	2070 mm
telescopic unit:	hydraulic
motor power:	1,5 kW
scale terminal:	ID7 from Mettler Toledo