



Handling



Dispensing



Sieving



Blending



Container



Cleaning

Validatable Automatic Washing

Containers, Drums and Process Machines (CIP)



SERVOLIFT
lifetime solutions

Your specialist for complete
handling-, blending and
cleaning technologies

► Washing System - CSW

The SERVOLIft washing system is designed for validated cleaning of all types of containers and pharmaceutical process equipment. The system features 4-step, easily programmable washing and is executed to the highest standards for GMP compliance. The system can be made portable in an easy to maneuver chassis or as a stationary system. We offer a wide range washing aids such as lift/lower devices for cleaning IBCs, turn table systems for aiding the operators in outside IBC washing and custom spray heads for all types of process equipment.

SERVOLIft GmbH
Albert-Einstein-Straße 9
77656 Offenburg Germany

T. +49 (0) 781 6100 0
F. +49 (0) 781 6100 400

info@servolift.de
www.servolift.de

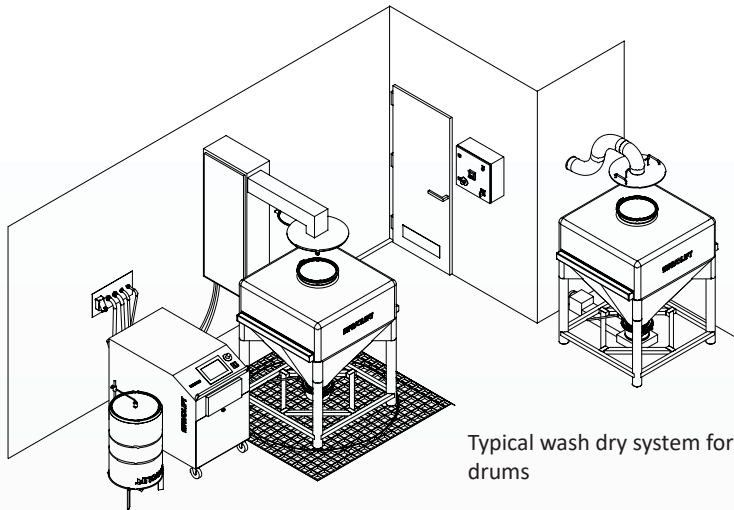

Typical wash dry system for IBC's and drums

ACCESSORIES



Washing lid for container



Washing head height adjustable



Washing system

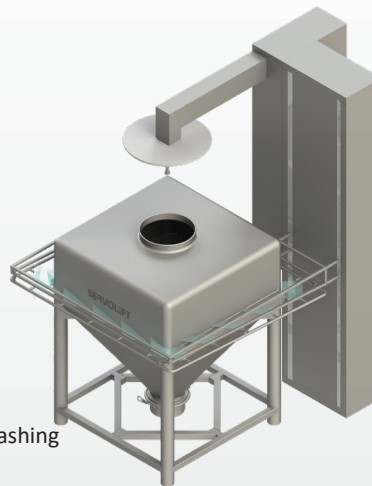

Inside and Outside washing

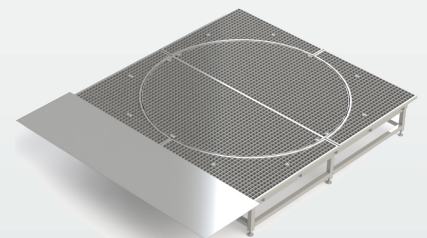

Turntable with drain pan for easier exterior washing

	Pre wash	Main wash	Rinse	Final rinse
Supply	Tap water 20-80 °C ca. 70 l/min min. 3 bar	Tap water 20-80 °C ca. 70 l/min min. 3 bar with / without dosing of detergent	Tap water 20-80 °C ca. 70 l/min min. 3 bar	Purified water 20-80 °C ca. 30 l/min min. 3 bar
Pressure	ca. 6-8 bar	ca. 6-8 bar	ca. 6-8 bar	ca. 3-8 bar

Technical Data:

- 4-step washing process
- Booster pump
- Volume flow, pressure and temperature monitoring
- Supply connections: Tri-Clamp
- Process connections: quick couplings
- All water lines purged with compressed air: 4 bar
- 2 suction lances for detergent dosing
- Main dimensions: circa (W x H x L) 950 x 1250 x 1400 mm
- Net weight: about 350 kg
- Mobile or stationary execution
- GMP compliant, stainless design
- Touchpanel, 15" colored, with process visualization
- PLC control in compliance with the GAMP 5 guideline with user, password and recipe management
- Printer for batch report



Washing support for drums

Additional options available:

- Control of main and dosing pumps to adjust the flow rate and for a flow dependent dosage of detergent
- Execution according CFR 21 part 11
- Washing head height adjustable
- Washing support for drums
- Turntable with drain pan for easier exterior washing
- Steam heat exchangers
- further accessories on request

The SERVOLIFT drying system CSD completes the cleaning products.