



Handling



Dispensing



Sieving



Blending



Container



Cleaning

# Blending has never been easier

## Blending with high flexibility



**SERVOLIFT**  
*lifetime solutions*

Experts in Handling,  
Blending and  
Cleaning Technology

### ► Blender

Since about 20 years SERVOLIFT sets the benchmark by „blending within a closed system“. The necessary blend quality is reached only by the square geometry of the container which requires no internal blend paddels. The blender design allows the handling of the container by common hand pallet jacks.

SERVOLIFT GmbH  
Albert-Einstein-Straße 9  
77656 Offenburg Germany

T. +49 (0) 781 6100 0  
F. +49 (0) 781 6100 400

info@servolift.de  
www.servolift.de

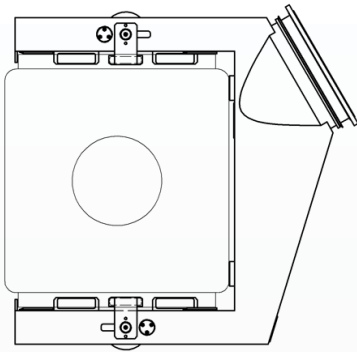

clamp system equipped with manual swivel clamp

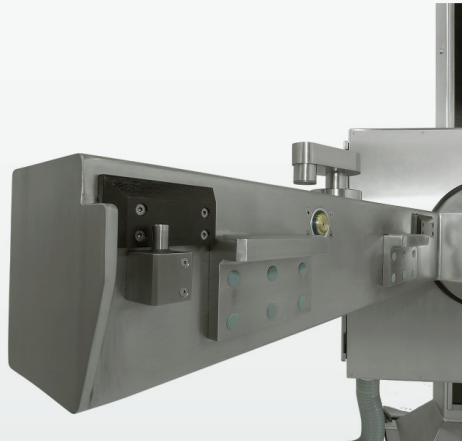
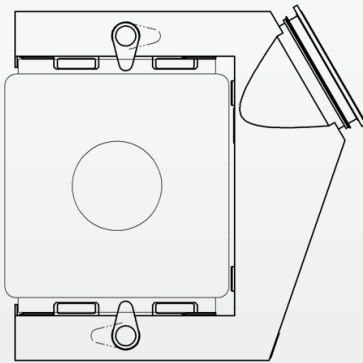

automatic clamp system equipped with two swivel clamps and two centring cylinders

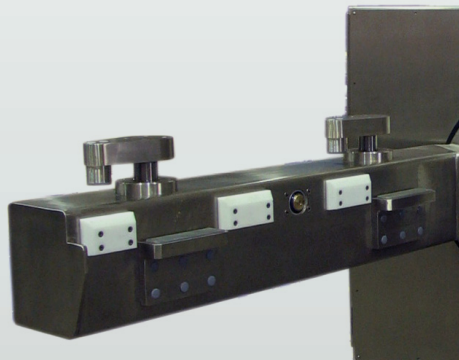
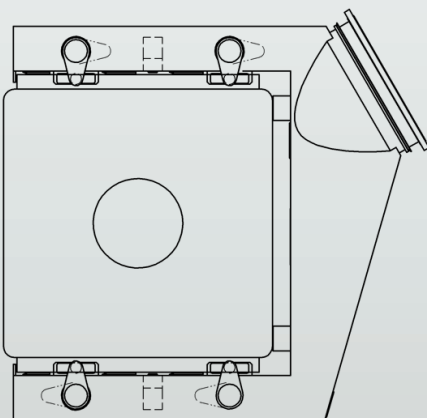

automatic clamp system equipped with four swivel clamps and four centring cylinders

### Overview of blending gears

\* further container sizes on request

clamp mode	number of clamps	max. load capacity	blend gear	size of container *	volume
manual	2	< 500 kg	NG 2000 / 4,5 kW	1000 x 1000 mm	600 Liter
manual	2	550 to 1000 kg	NG 4000 / 5,5 kW	1000 x 1000 mm	1300 Liter
automatical	2	550 to 1000 kg	NG 4000 / 7,5 kW	1000 x 1000 mm	1300 Liter
automatical	4	600 to 1000 kg	NG 4000 / 7,5 kW	1200 x 1200 mm	1300 Liter
automatical	4	1050 to 1800 kg	NG 5000 / 11,0 kW	1200 x 1200 mm	2600 Liter