



Handling



Dispensing



Sieving



Blending



Container



Cleaning

Ultra-easy Container Handling all-purpose



SERVOLIFT
lifetime solutions

Your specialist for
complete handling-, blending-
and cleaning technologies

► Container Lifter

The container lifter was especially designed for feeding of tablet presses, but is also suitable for all applications in which products are emptied from containers by gravity.

Distinguishing features of the stationary lifting column include its compact design and user friendly operation. An exhaustive and time-consuming positioning of the container for the emptying process is no longer required. Once the container is set in place, it is automatically moved into the feeding or discharging position.

With various options and accessories, our lifting column can be transformed into a complete emptying station comprising diverse process steps.

We will gladly advise you.

SERVOLIFT GmbH
Albert-Einstein-Straße 9
77656 Offenburg Germany

T. +49 (0) 781 6100 0
F. +49 (0) 781 6100 400

info@servolift.de
www.servolift.de

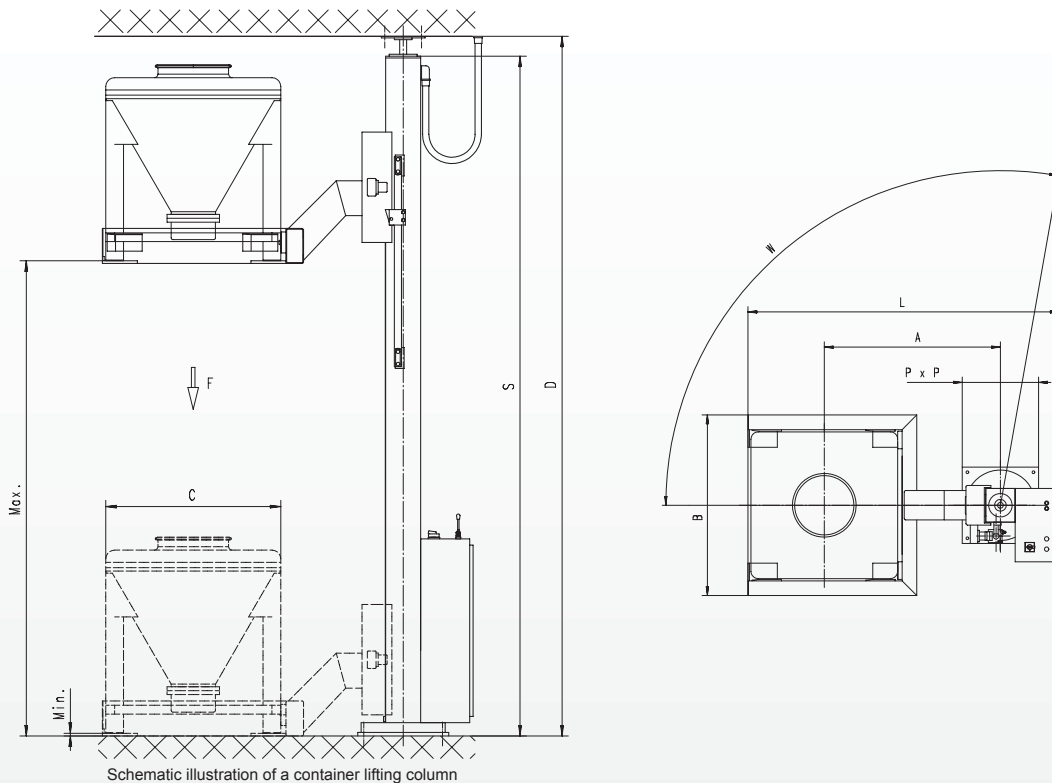

Index	Description	Measurements	Example
F	Max Load capacity	According to customer specifications, 1 kg - 1800 kg	800 kg
D	Ceiling height	According to customer specifications	4000 mm
C	Container size (side length)	According to customer specifications	1000 mm x 1000 mm
W	slewing angle	According to customer specifications, max. 270°	94°

S	Column height	D - 125 mm	4000 mm - 125 mm = 3875 mm
Max	Maximum lift	D - 1100 mm (min.), depending on the load capacity and overhang	4000 mm - 1250 mm = 2750 mm
Min	Minimum lift	15 mm	
A	Overhang Column slewing axis - middle of the container	800 mm - 1500 mm depending on the load capacity and the container size	1400 mm
L	Length of the unit, incl. support arm	$A + C / 2 + 475$ mm	$1400 \text{ mm} + 1000 \text{ mm} / 2 + 475 \text{ mm}$ = 2375 mm
P	Base plate (*) in mm	520 x 520 for an F < 500 kg 620 x 620 for an F of 500 kg to 1250 kg 770 x 770 for an F of 1250 kg to 1800 kg	620 mm x 620 mm
B	Width of support arm	C + 80 mm < 800 kg load capacity C + 260 mm > 800 kg load capacity	1000 mm + 80 mm = 1080 mm

(*) These dimensions will be different for lifting columns without ceiling support and/or long overhang.

These specifications apply to our standard lifting columns. We will gladly provide you with a drawing if you have different specifications.